

K-Brush Conveyor Belt Cleaners



For difficult conveyor belt cleaning and product finishing applications the K-Brush Conveyor Belt Cleaner is designed for the job especially where space limitations apply.

It is ideally suited to cleated, chevron, reversible and mechanically joined belts. For heavy duty applications refer to our DM series.

This standardized and compact cleaning system will sweep the belt or surface clean with a rotary action. Wet, dry, sticky, hygroscopic, statically charged and abrasive products can be cleaned off the belt.

The unit is designed for difficult applications including salt, sugar, fertilizer, wood dust, cement dust and carbon black.

K-Brush Conveyor Belt Cleaner consists of a power driven standardised modular brush assembly. The segmented brushes are constructed from non corroding polyethylene. The bristles are an abrasive resistant polypropylene. A wide variety of bristle types and configurations are available.

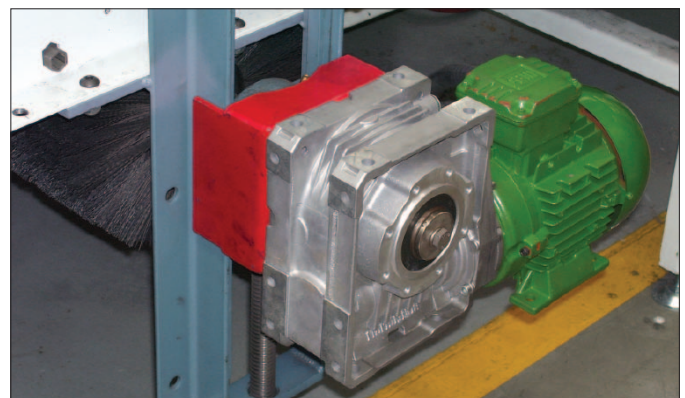

K-Brush Conveyor Belt Cleaners

CLEANER- K-BRUSH MOTORIZED ASSEMBLY TYPE LM

BELT WIDTH:- 450 - 900
DRAWING No.1023 R2

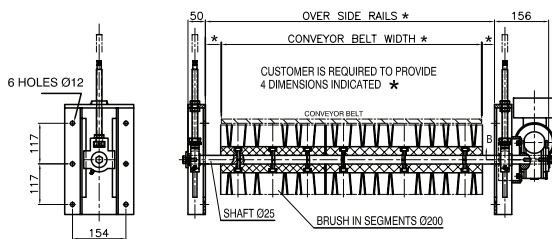

CLEANER- K-BRUSH MOTORIZED ASSEMBLY TYPE DM

BELT WIDTH:- 750 - 1800
DRAWING No.1017 R2

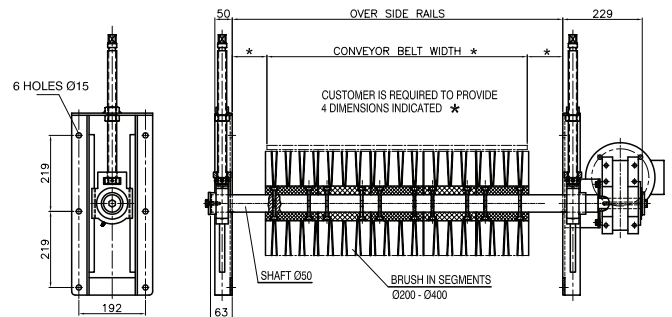

CLEANER- K-BRUSH MOTORIZED ASSEMBLY TYPE 1000

BELT WIDTH:- 750 - 2000
DRAWING No.1354 R1

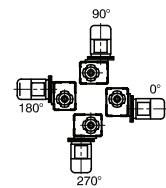
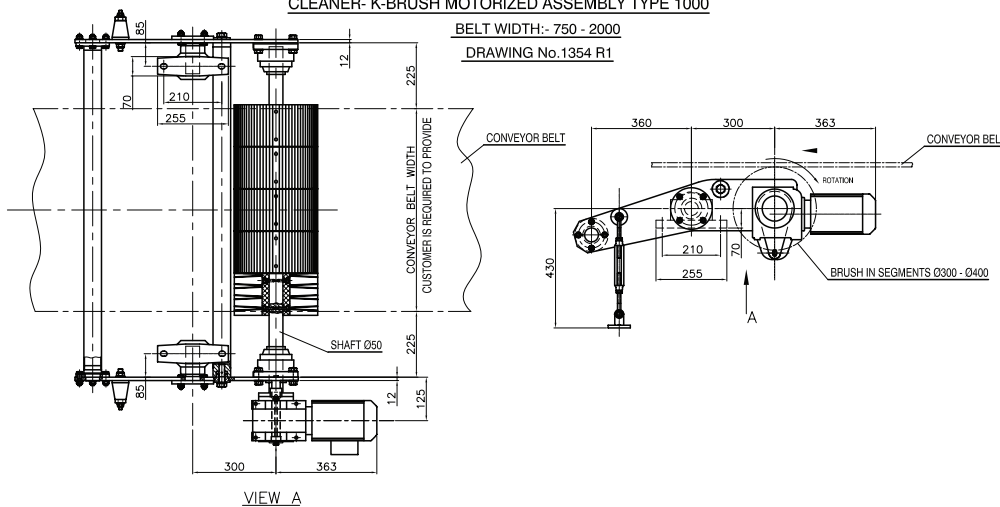

MOTOR ORIENTATION
FOR ALL TYPES
THE GEARMOTOR CAN BE
MOUNTED AS SHOWN
INDICATE ORIENTATION REQUIRED

Specifications subject to change without notice.
Certified drawings are available on request.